



Assembling the LCR-T4 Mega328 Tester Kit



by Joseph Murchison

I ordered the LCR-T4 Mega328 transistor tester diode triode capacitance ESR meter with shell from Banggood. Most of my testers are much larger and don't test inductors. This tester will fit in your pocket.

LCR-T4 Mega328 Tester Kit

I opened the package when it arrived in the mail and tested the circuit board with a 9 volt battery I had and it worked. However it didn't have assembly instructions for the acrylic shell, so here are some tips on how to assemble the tester easily. Done right you can be finished in 15 minutes.

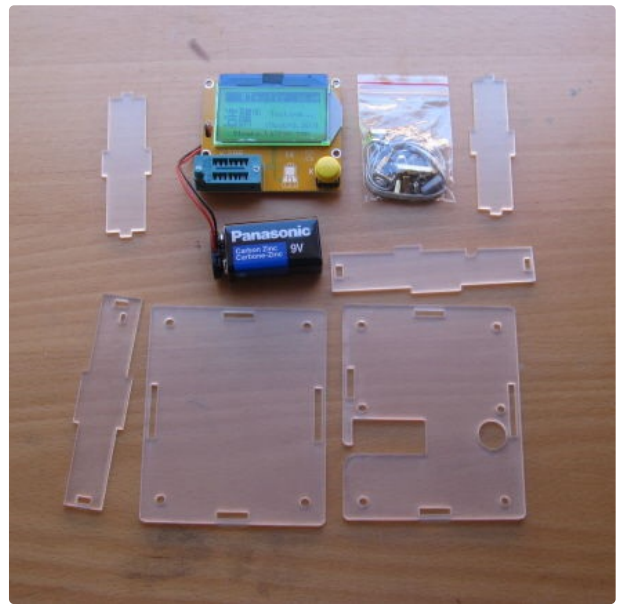
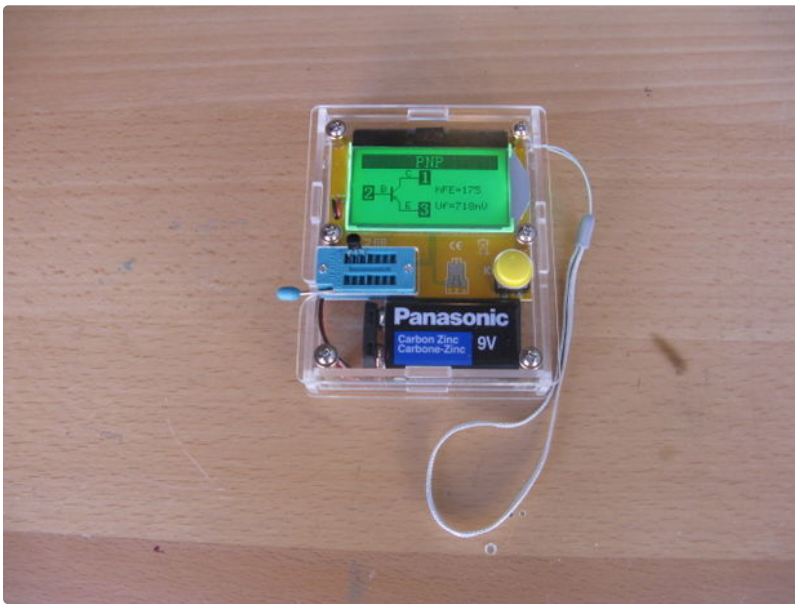

Step 1: Tools & Parts

Gather what you need first.

1 x Phillips screwdriver

1 x Small or needle nose pliers

1 x 9 volt battery not supplied in the kit.

2 x short female standoffs

2 x long female standoffs

1 x assembled circuit board

1 x LCR-T4 Mega328 Transistor Tester Diode Triode
Capacitance ESR Meter With Shell Kit

The Kit Includes:

10 x screws

4 x male standoffs

1 x acrylic case in 6 pieces

1 x lanyard

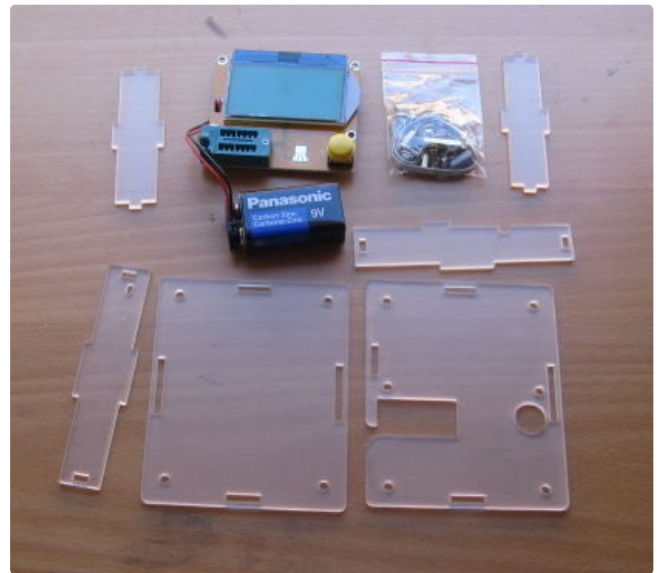

Step 2: Attach the Male Standoffs First

The fit of the screws in the front cover; is much looser than the fit of the standoffs in the circuit board, and you may need to screw the male standoffs into the circuit board.

Start by putting the 4 male standoffs in the front of the circuit board screwing them in if necessary.

Put the two nuts on the male standoffs on the bottom of the circuit board.

Put the two short female standoffs on the male standoffs on the top of the circuit board.

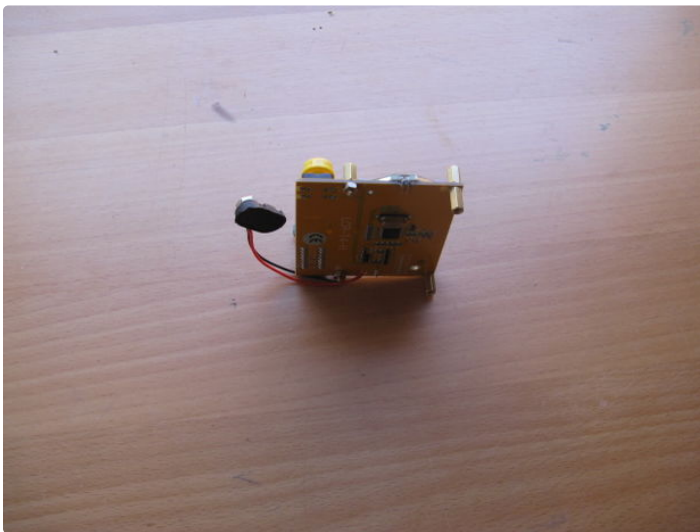
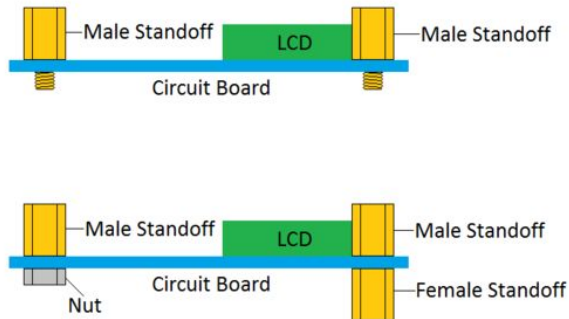

Step 3: The Protective Coating

Remove the protective coating from the acrylic panels before you attach them to the circuit board and assemble the case. You do this by catching the edge of the coating with your thumbnail or something sharp and peeling it off.

If you do not remove the protective coating you will only have to disassemble the case and then reassemble it after you have removed the protective coating.

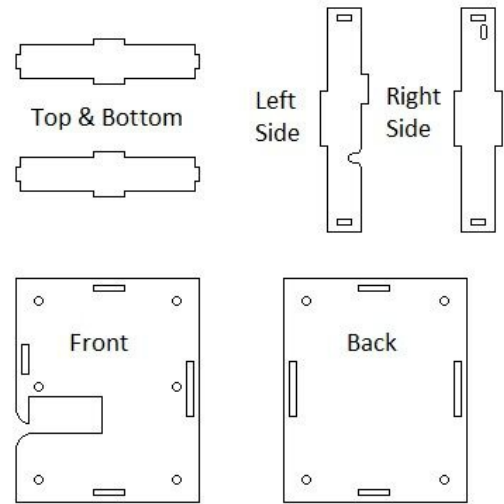
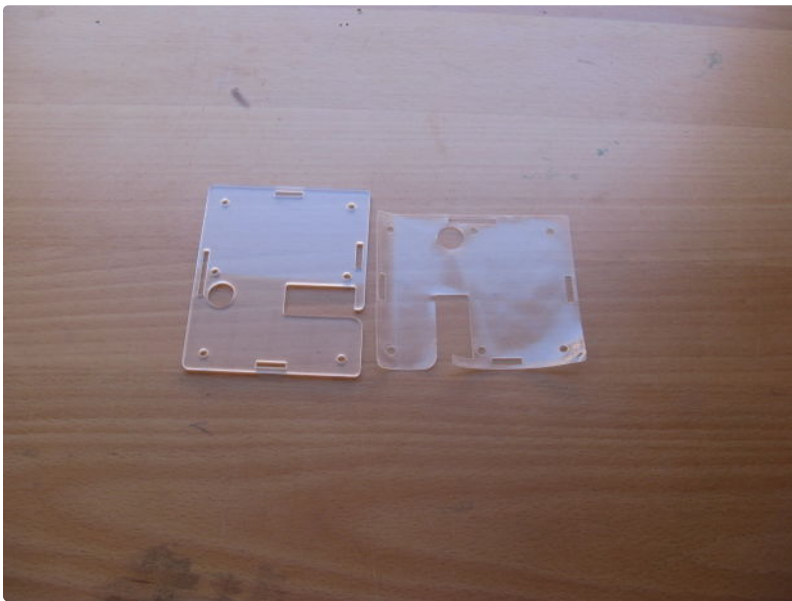

Step 4: Attaching the Front Cover

Making sure you match the button hole, ZIF socket, (Zero Insertion Force Socket), and the 4 screw holes on the 4 standoffs on the circuit board, place the front cover on the circuit board and screw it tight with 4 of the screws.

Next attach the 2 long standoffs to the 2 remaining holes in the bottom of the front cover with 2 screws.

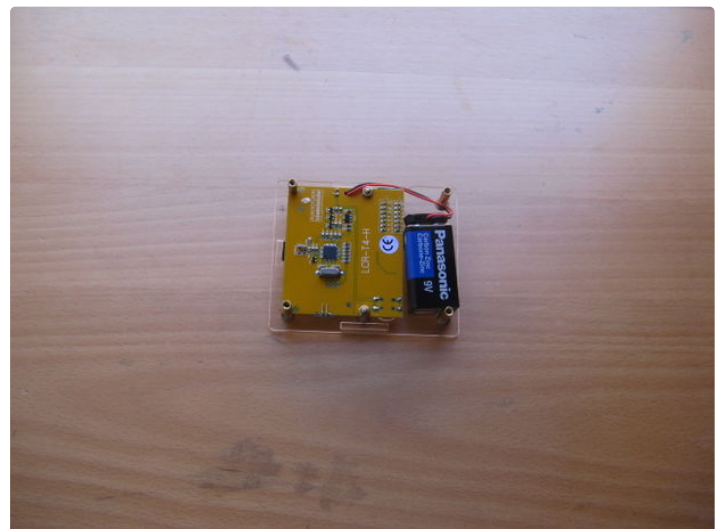
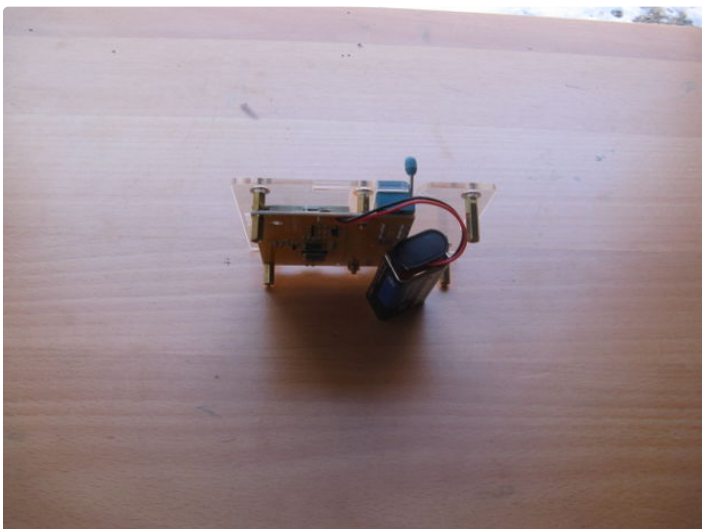
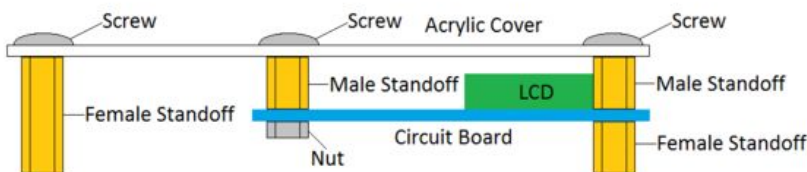

Step 5: Attaching the Sides

The top and the bottom sides are identical and notch into the right and left side, so I put them in place first.

The right side has a hole for the lanyard; so I put the small loop of the lanyard through the hole and looped it around the top right standoff when I put the right side in place.

The left side; has a notch for the arm of the ZIF

socket, line the notch for the ZIF socket up with the ZIF socket and put the left side in place.

There is no room between the circuit board and the sides for anything, so make sure the battery wires pass under the circuit board and not between the circuit board and the left side.

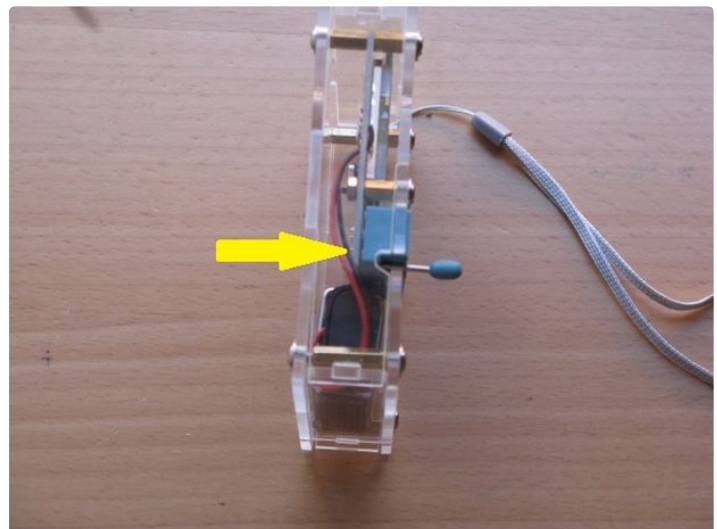
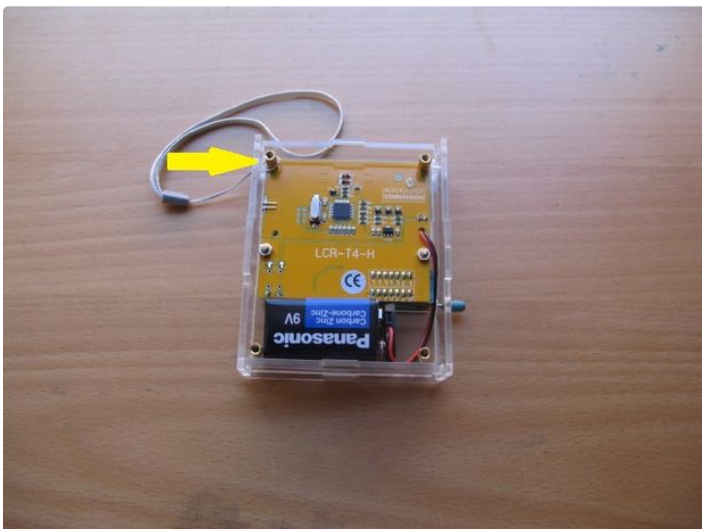
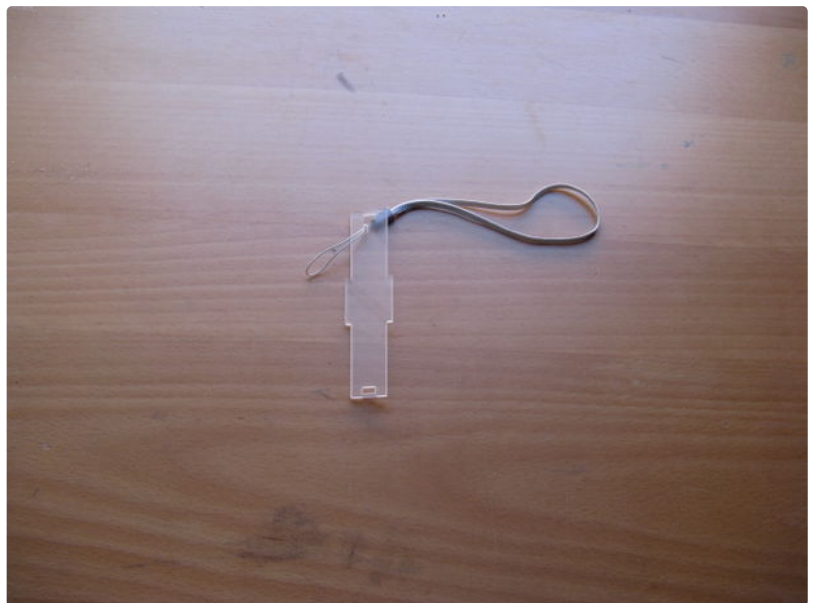

Step 6: Attaching the Back

Once the sides were in place I put the back on and screwed it down with the 4 remaining screws completing the tester's case. Now I am ready to do some testing.

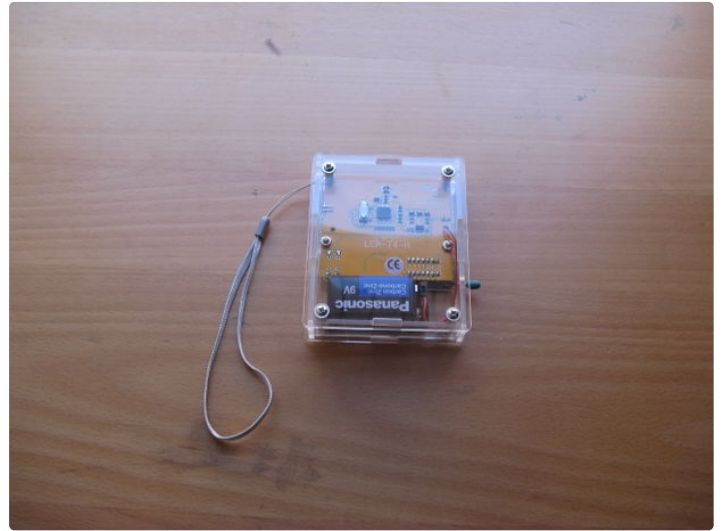

Step 7: Testing and Specifications

Here I inserted a BC557 transistor and compared the reading to the transistors datasheet.

Specifications:

Resistor: 0.1 Ω -50M Ω

Capacitor: 25pF-100000uF

Inductance: 0.01mH - 20H

Working power: DC-9V

Standby current: 0.02uA

Operating current: 25mA

Material: Metal+Plastic

Size: about 11.1cm/4.37"x2.6cm / 1.02"x8.5cm/3.34"

[Conversion: 1cm=0.3937 inch, 1inch=2.54 cm]

Description:

1. Add boot voltage detection function
9. Power consumption off mode: less than 20 nA of
10. Auto power off function to avoid unnecessary

2. Automatic detection of NPN and PNP transistors, N-channel and P-channel MOSFET, diodes (including dual diode), thyristors, transistors, resistors and capacitors and other components

3. Automatic test out the pin element and displayed on the LCD

4. Can be detected to determine the transistor emitter forward bias voltage of the transistor, MOSFET protection diode and the amplification factor of the base

5. Measure the gate threshold voltage and gate capacitance of the MOSFET

6. 1602 lcd display uses LCD (12864 LCD with backlight)

7. High test speed, valid component test: 2 seconds (except in the larger capacitor of large capacitance measurement also takes a long time, the measured time of one minute is normal)

8. One button operation, power-on test, get a key waste, saving battery power, improved battery life.

